

# 275 Series - Motor Reversing Contactor

## 2X - 3PST, 15 Amp



The 275 series is a 2 coil, compact motor reversing contactor which finds extensive applications in the industrial door operator industry, the hoist industry and electronic wheel balancers, to name a few. The 275 series has Quick connect coil terminals extending out the back (opposite the contact terminals), mechanically interlocked armatures is a standard feature.

### GENERAL SPECIFICATIONS (@ 25° C)

#### Contacts:

Contact Configuration	3PST-NO Double Make per side
Contact Material	Silver alloy
Contact Rating	
120 / 240VAC Resistive	15 Amp / 10 Amp
Motor 120VAC 1 Phase	1Hp
Motor 240VAC 1 Phase	1.5Hp
Motor 240VAC 2-3 Phase	3Hp
Motor 480 / 600VAC 2-3 Phase	3Hp
Contact Resistance, Initial	100milliohms max @ 6VDC

#### Coil:

Coils Available	AC and DC
Nominal Coil Power	17VA 4.9W
Input Voltage Tolerance - AC	85% to 110% of nominal
Input Voltage Tolerance - DC	80% to 110% of nominal
Drop-out voltage	10% of nominal
Duty	Continuous

#### Timing:

Operate Time (max)	50mS
Release Time (max)	30mS

#### Dielectric Strength:

Across Open Contacts	2500 VRMS
Between Mutally Insulated Points	2500 VRMS
Insulation Resistance	1000 Megohms @ 500 VRMS

#### Temperature:

Operating	-34 to 74°C (-30 to 165°F)
Storage	-40 to 105°C (-40 to 221°F)

#### Life Expectancy:

Electrical (full load operations)	100,000
Mechanical (no load operations)	5,000,000

#### Miscellaneous:

Mounting Position	Vertical , Contacts Up
Enclosure	Semi-Enclosed
Weight	16.0oz (406 grams)

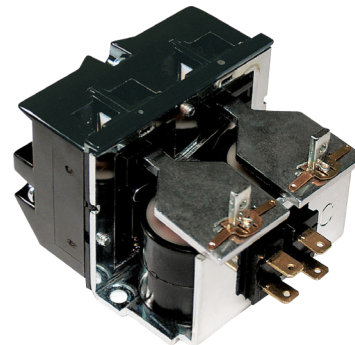

#### 275KXX - Resting Position

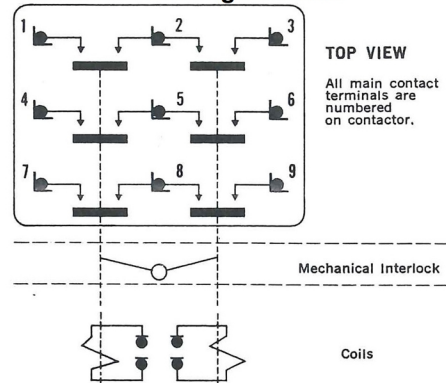

#### 275KXX90 or 91 Resting Position

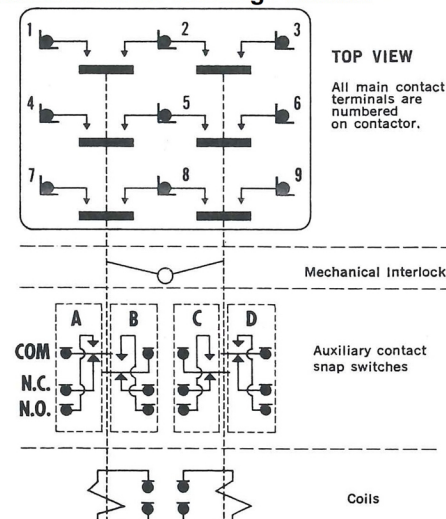

# Motor Relays

## 15 - 75 Amp

### Outline Dimensions

Dimensions Shown in inches & (millimeters)

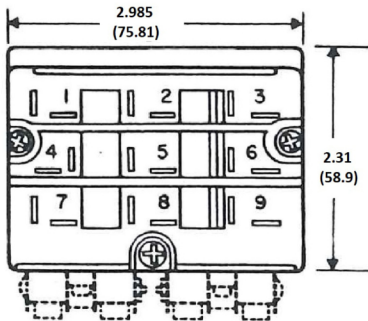

**NOTE:**

Auxiliary contact snap switches shown in broken lines.  
 Switches A and D supplied on A275KXX90.  
 Switches A, B, C and D supplied on A275KXX91.

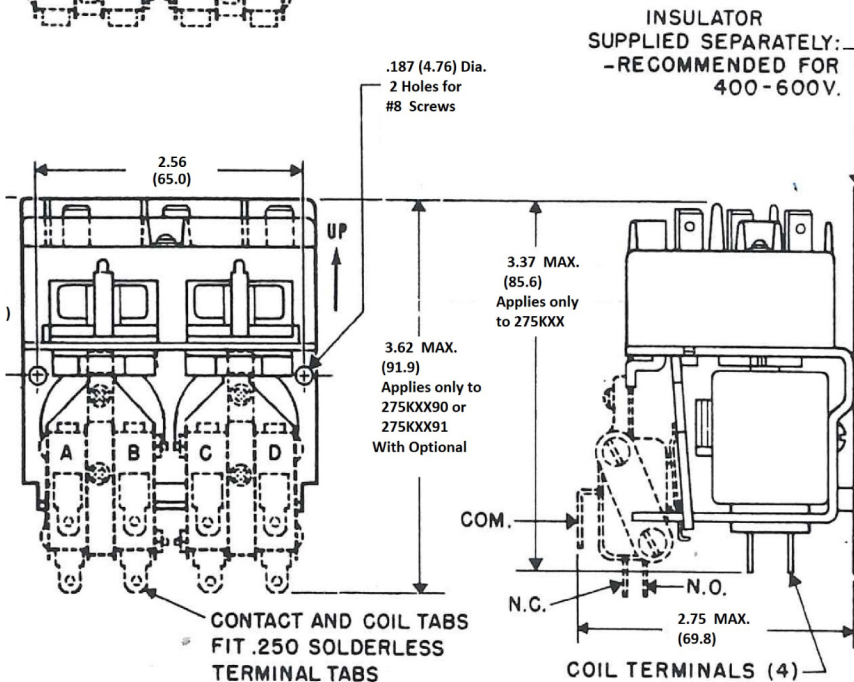

UP  
  
 Recommended Mounting Position

**Ordering Code**    275    KXX    90    -24VAC

**series** ————  
 275

**Contact Arrangement** ————  
 KXX (2X 3PST – N.O. – double make)

**Optional Features** ————  
 2 Auxiliary contacts each SPDT  
 (1 per coil) .25" quick connect terminals - CODE 90  
 4 Auxiliary contacts each SPDT  
 (2 per coil) .25" quick connect terminals - CODE 91  
 Rectified coil - CODE V2

**Coil Voltage** ————  
 AC: 24, 120, 240 (Add VAC)  
 DC: 12, 24, 125 (Add VDC)

### Coil Specifications

AC Coil, 50/60HZ		DC Coil	
Nominal voltage	Resistance ohms ±10%	Nominal voltage	Resistance ohms ±10%
12	1.24	12	31
24	4.63	24	125
110-120	125	32	210
220-240	500	48	500